

3rd NCWG MEETING
ESRI HQ, Redlands, California, USA 16-19 May 2017

Paper for Consideration by NCWG

Rocks, which do not cover: US minimum-size symbol for islets

Submitted by:	USA (NOAA)
Executive Summary:	Provides information about US raster chart symbol for small islets and rocks, which do not cover.
Related Documents:	NCWG3-08.6A, S-4, S-52, INT1
Related Projects:	

Introduction / Background

The Italian Hydrographic Office submitted the paper [NCWG3-08.6A](#), “Rocks which do not cover: do we need a new point symbol?” To which the United States answers, “Yes, S-4 should provide guidance for use of a new symbol.” However, NOAA recommends a symbol that we believe has advantages over the “X” symbol that has been proposed.

Analysis / Discussion

NOAA uses a line weight of 0.25 mm for natural coastline. . Representing any single islet with a dot, not “less than the width of the coastline symbol,”¹ could still be as small as the period at the end of this sentence. Therefore, NOAA uses a “minimum-size islet” symbol, which is a land-tint filled 0.65 mm by 0.5 mm oval, enclosed with a 0.1 mm weight black line. An oval is used instead of a circle so it will look less like a manmade feature. An enlarged image of this symbol with its associated height is shown below, at left.

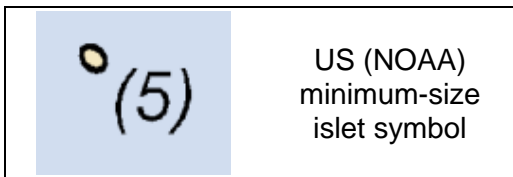

These two symbols are not shown at the same scale.

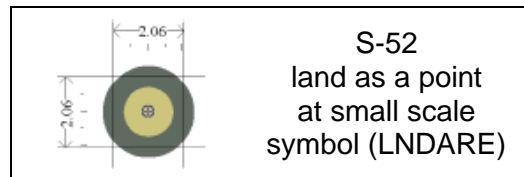

Any islet or rock, which does not cover, that would be smaller than 0.65 mm by 0.5 mm at chart scale is represented with this symbol. The S-52 symbol library, used by ECDIS, has a similar symbol for “land as a point at small scale,” shown above, at right (see the S-52 specification for the LNDARE01 symbol in Annex A).

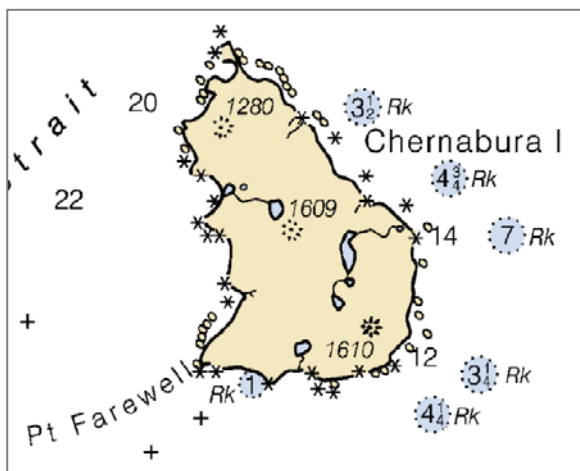

The image at left from, [NOAA Chart 16540](#), shows use of the minimum-size islet symbol in context.

There is some appeal for using an X symbol for islets, because it seems like a logical extension of the rock family of symbols made up of two or three crossed lines. However, the family resemblance of the X with its other rock cousins is also its great weakness.

One can easily see that orienting the chart image at left from north-up to NW, NE, SE, or SW up will instantly transform the rocks off shore from Point Farewell from submerged rocks into islets. Similarly, any X symbols used to depict islets could easily be mistaken for submerged rocks when a paper chart is rotated or its corresponding RNC is displayed in an ECS that is not in north-up mode.

¹ IHO S-4, section B-421.1

Regardless of what symbol might be selected, the critical point of Italy’s paper, which the US whole heartedly agrees with, is that the current S-4 guidance of, “must not be reduced to a width less than the width of the coastline symbol (to avoid confusion with printing imperfections),” is entirely inadequate.

The only reason the smaller symbol in K10 is noticeable is that the green intertidal area is also depicted. This would not be a case in areas with little or no tidal fluctuation. It is also likely that the intertidal area of many islets would not be determined, because it would be so small or dangerous to measure amongst a cluster of other rocks, a common occurrence in glaciated areas.

The current INT1 K10 entry is shown below.

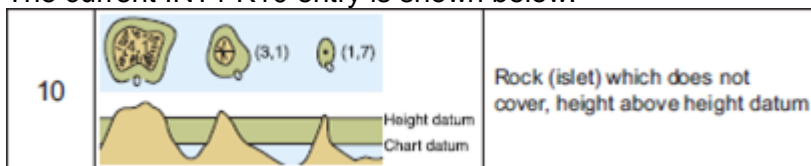

In any event, because the area of the islet is smaller than the minimum-size symbol, it is likely that its intertidal area would also not extent past the land-tint of the symbol either. Therefore, it is recommended that guidance be provided to use only the minimum-size land tint symbol.

A new minimum-size islet symbol might be depicted in K10 as shown below.

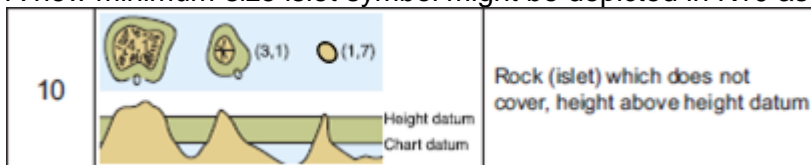

The portions of S-4 sections B-310.2 and B-421.1 that provide guidance on the depiction of islets too small to be shown to scale should be changed to read:

“Islets too small to be shown to scale should be depicted with a minimum-size islet symbol at least 0.5 mm wide, consisting of land tint enclosed by a black shoreline.

Conclusions

There is a need to refine the guidance in S-4 and the symbols depicted in INT1 for “Rock (islet) which does not cover” and to establish a “minimum-size islet” symbol to depict islets that are smaller than 0.5 mm (or some other agreed upon size) at chart scale. The US proposed symbol is easy to see by itself (without an intertidal area), unambiguous in all orientations, uses land-tint to indicate that the feature is always bare, and is consistent with the corresponding ECDIS symbol.

Recommendations

Consider the merits of the proposals for improving the depiction of islets and small rocks, which do not cover, as put forth here and in NCWG3-08.6A. Make the appropriate changes to S-4 and INT1.

Action required of NCWG

The NCWG is invited:

- Agree to or make adjustments to this proposal to improve S-4 guidance for the depiction of small islets and rocks, which do not cover
- Make the appropriate changes to S-4 and INT1.

ANNEX A

Symbol Name:	SY(LNDARE01)	RN: 162
--------------	--------------	---------

Symbol Explanation: land as a point at small scale

Look up table affected: paper chart point symbols
simplified point symbols

Pivot Point Column: 1.03
Pivot Point Row: 1.03

Width of Bounding Box: 2.06
Height of Bounding Box: 2.06

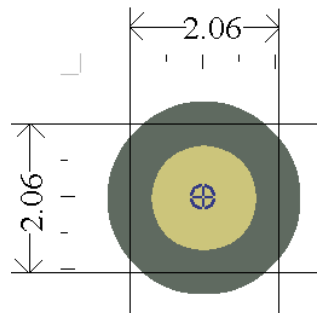

Symbol Colours:



Comments: Circle outline weight 0.6 mm; circle diameter 2.06 mm

Examples on ENC: N/A

References:

S57	INT 1	
LNDARE	K 10	<p>The examples show three points with heights (4.1), (3.1), and (1.7) and a cross-section diagram with height datum and chart datum labels.</p>